

Industrial Automation System

Amit Verma, Ankit Kumar, Avdesh Sikarwar

Abstract— This paper describes how the present instrumentation system comes into existence through its various stages. In the past, automation is done through relays and contactor logics. Automation is closely related to the modern need for sustainable development in the 21st century. One of the principles of sustainability is "Doing More with Less" which in other words, is also one of the goals of automation. By replacing the routine part of human labor with the use of machines, automation not only increases productivity and the quality of products beyond what can be achieved by humans but also frees space, time and energy for humans to deal with the new, non-routine challenge of developing innovative and more advanced technologies.

Index Terms— instrumentation, Automation, technologies

I. INTRODUCTION

Automation, a Greek word means "self-dedicated". Automation is the key to modernization and has been conceptually understood as a way to increase efficiently and to improve productivity. The process of having machines follow a predetermined sequence of operation with little or no human labor, using special equipment and devices that perform and control manufacturing processes is known as automation. The goals of automation are Integration of various aspects of manufacturing operations to reduce labor cost, To improve productivity or efficiency, To improve quality, To reduce human involvement therefore human error, To reduce work piece damage that manual handling caused, To raise the safety level. The fundamental constituents of any automated process are (1) a power source, (2) a feedback control mechanism, and (3) a programmable command (as shown in figure 1) structure. Programmability does not necessarily imply an electronic computer.

Here, the automated process proceeds without any direct and continuous assessment of the effect of the automated activity. For example, an automated car wash typically completes its task with no continuous or final assessment of the cleanliness of the automobile.

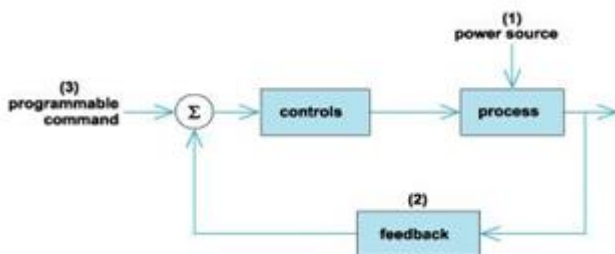

Figure. 1 FEEDBACK MECHANISM

Amit Verma, Electronics & Instrumentation (Dept.), ITM Gwalior
Ankit Kumar, Electronics & Instrumentation (Dept.), ITM Gwalior
Avdesh Sikarwar, Electronics & Instrumentation (Dept.), ITM Gwalior

AUTOMATION TOOLS

- I. Relays and contactor logic
- II. Programming logic controllers (PLC)
- III. Supervisory control and data acquisition (SCADA)
- IV. Distributed control system (DCS)

A. RELAY SYSTEM

A relay is an electrical switch that opens and closes under control of another electrical circuit. In the original form, the switch is operated by an electromagnet to open or close one or many sets of contacts. The general functions of relays are protection, monitoring and control. If the coil is energized with DC, a diode is frequently installed across the coil, to dissipate the energy from the collapsing magnetic field at deactivation, which would otherwise generate a spike of voltage, and might cause

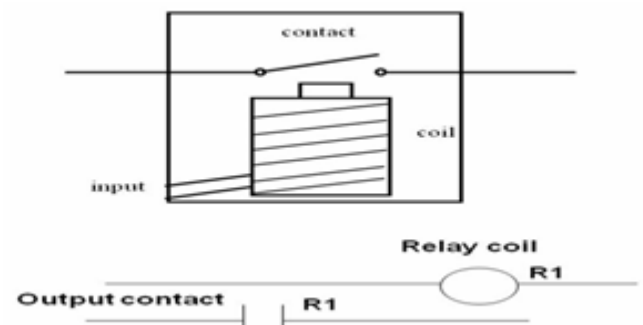

damage to circuit components. Alternatively a contact protection network, consisting of a capacitor and resistor in series, may absorb the surge. If the coil is designed to be energized with AC, a small copper ring can be crimped to the end of the solenoid. This "shading ring" creates a small out-of-phase current, which increases the minimum pull on the armature during the AC cycle. Relays found a wide application in various fields: - To control a high-voltage circuit with a low-voltage signal, as in some types of modems, To control a high-current circuit with a low-current signal, as in the starter solenoid of an automobile To detect and isolate faults on transmission and distribution lines by opening and closing circuit breakers (protection relays), To isolate the controlling circuit from To perform logic functions logic networks.

Disadvantages of Relay System

- 1) The maintenance cost of the relay system is quite high, as the frequent maintenance is required in it.
- 2) A driver circuit is required along with larger relays.
- 3) Very high human intervention is required in this system.
- 4) They do not allow manual adjustment of the relay state

when the control power is off.

- 5) These are only use for ON/OFF control. Intermediate controlling is not possible by the relays.
- 6) They increased electrical noise when conducting.

B. CONTACTOR LOGIC

A contactor is an electrically controlled switch (relay) used for switching a power circuit. A contactor is activated by a control input which is a lower voltage / current than that which the contactor is switching. Contactors come in many forms with varying capacities and features. Unlike a circuit breaker a contactor is not intended to interrupt a short circuit current. Basic Features of Contactor Logic are as follows:

A contactor is composed of three different systems. The contact system is the current carrying part of the contactor. This includes Power Contacts, Auxiliary Contacts, and Contact Springs. The electromagnet system provides the driving force to close the contacts. The enclosure system is a frame housing the contact and the electromagnet. Enclosures are made of insulating materials like Bakelite, Nylon 6, and thermosetting plastics to protect and insulate the contacts and to provide some measure of protection against personnel touching the contacts. Open-frame contactors may have a further enclosure to protect against dust, oil, explosion hazards and weather.

The major disadvantage of relays and controller logic is that it does not have any redundant system it means that if system fails then, it does not have any controlling system to continue its controlling and monitoring process. So if system fails then we have to rectify the control system so that controlling & monitoring could be restarted.

II. PROGRAMMING LOGIC CONTROLLER

A digitally operating electronic apparatus which uses a programmable memory for the internal storage of instructions by implementing specific functions such as logic sequencing, timing, counting, and arithmetic to control, through digital or analog input/output modules, various types of machines [1]. Architecture of PLC is shown in figure 3.

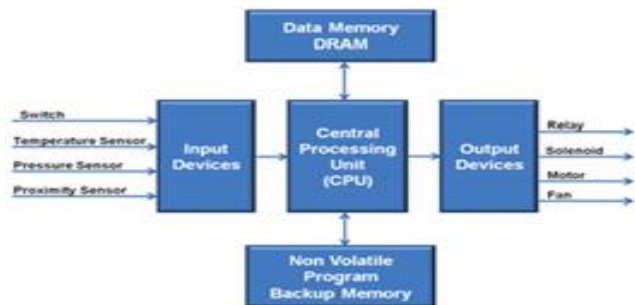

Figure. 3 BLOCK DIAGRAM OF RELAY

PLC has 4 main units:-

- 1) Programmable Memory- The instruction for logical control sequence is stored here
- 2) Data Memory- The status of the switches interlocks, past values of data and other working data is stored here.
- 3) O/P Devices- These are hardware or software drives for

industrial process actuators, such as solenoid, switches, motor and valves.

- 4) I/P Devices- These are hardware or software driver for industrial process sensors such as switch status sensors, proximity detectors interlock setting.

III. WORKING PRINCIPAL OF PLC

Ladder logic programming method is used for working of PLCs. In this logic the power is on vertical line on the left hand side, on the right hand side is the neutral rail as in the figure 4 there are two rungs and on each rung there are combination of input and output , if the input are open or closed in the right combination

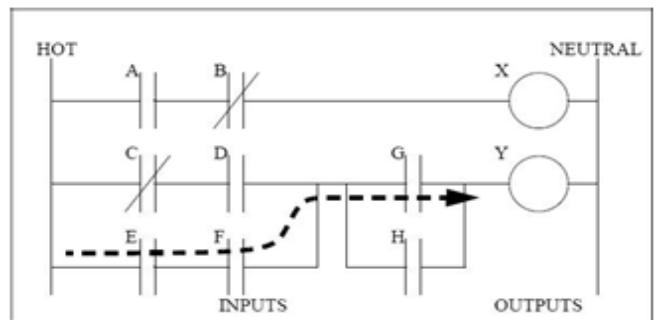

Figure. 4 PLC WORKING

the power can flow from the hot rail through the inputs to power the output and finally to the neutral rail. An input come from a sensor and output will be some devise outside the Plc,

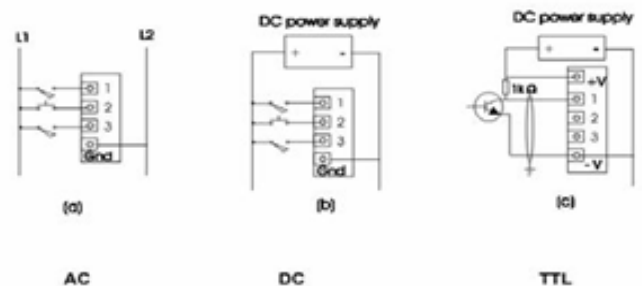

Figure. 5 INPUT CONNECTIONS

that is switched on or off such as motor, inthe top rung the contacts are normally open (NO) or normally closed (NC) . Which means if input a is on and b is off the power will flow through the output and activated. Any other combination of input values will result in the output x being off [2]. The input connections (figure.5) and output connections (figure.6) are shown.

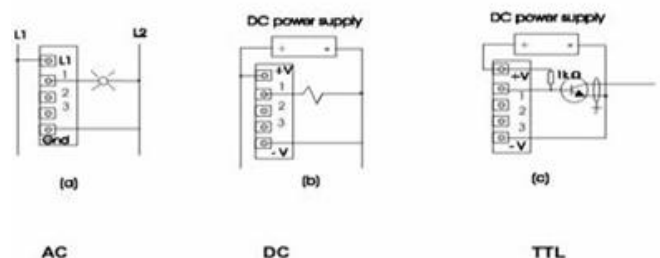

Figure. 6 OUTPUT CONNECTIONS

Scanning Principle of PLC

A PLC resolves the logic of a ladder diagram (program) rung by rung, from the top to the bottom. Usually, all the outputs are updated based on the status of the internal registers. Then the input states are checked and the corresponding input registers are updated.

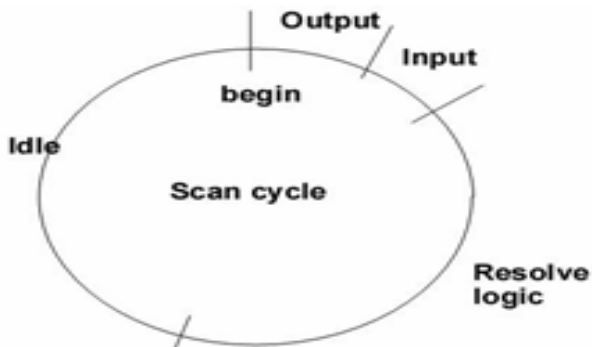

Figure. 7 SCAN CYCLE OF PLC

Only after the I/Os have been resolved, is the program then executed. This process is run in an endless cycle. The time it takes to finish one cycle is called the scan time. In some controllers the idle state is eliminated. In this case, the scan time varies depends on the program length.

Advantages Of Using Plc's are as follows:

- 1) Cost effective for controlling complex systems.
- 2) Flexible and can be reapplied to control other systems quickly and easily.
- 3) Computational abilities allow more sophisticated control.
- 4) Trouble shooting aids make programming easier and reduce downtime.

Reliable components make these likely to operate for years before failure.

IV. SCADA

SCADA is an acronym that stands for Supervisory Control and Data Acquisition. SCADA, a computer system, for gathering and analysing real time data. SCADA systems are used to monitor and control a plant or equipment in industries such as Tele-communications, water and waste control, energy, oil and gas refining and transportation [3],[4].Component used in SCADA are as follows:

1. Remote Terminal Unit(RTU):-RTU is a device installed at a remote location that collects data, codes the data into a format that is transmittable and transmits the data back to a central station, or master. An RTU also collects information from the master device and implements processes that are directed by the master.

2.Master Terminal Unit (MTU):-The term "Master Station" refers to the servers and software responsible for communicating with the field equipment (RTUs, PLCs, etc), and then to the HMI software running on workstations in the control room, or elsewhere.

3.Field Instrumentation: - It refers to the devices that are

connected to the equipment or machines being controlled and monitored by the SCADA system[5]. These are sensors for monitoring certain parameters; and actuators for controlling certain modules of the system.

usually not Accessible by telephone lines. The use of radio offers an economical solution. Modems are used to connect the remote sites to the host [6].

In the SCADA for the controlling operation there are basically three types of configuration used for all types of control measurement. They are as follows:-

- 1) Point To Point control system configuration.
- 2). Point To Multipoint control system Configuration.
- 3.) Peer To Peer control system configuration.

HMI system in SCADA

A SCADA system includes a user interface,

usually called Human Machine Interface (HMI). The HMI of a SCADA system is where data is processed and presented to be viewed and monitored by a human operator. This interface usually includes control where the individual can interface with the SCADA system [7].

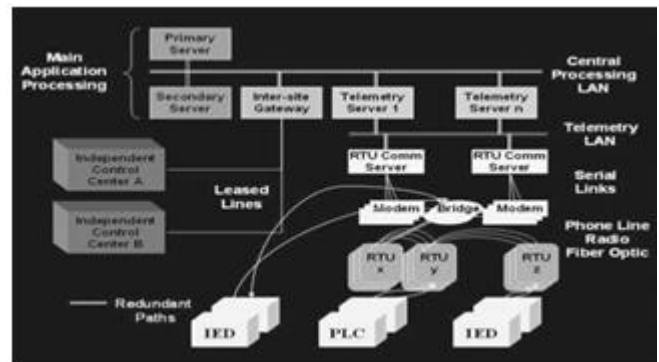

Figure 8 SCADA SYSTEM AND IT'S COMPONENT

4.Communication Network:- Communication network refers to the communication equipment needed to transfer the data to and from different sites to the central station. The medium used can either be cable or telephone. Remotes are more

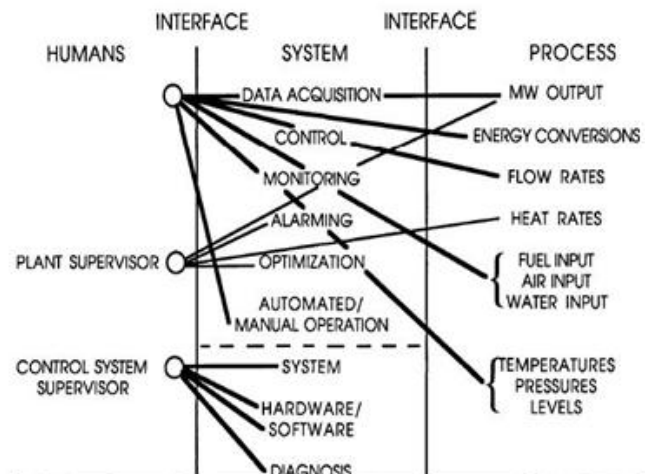

Figure.9 HUMAN/SYSTEM/PROCESS INTERFACE

Limitation of SCADA system:-

Real-time information on the system is required to affect improved, speedier and more accurate switching [7]. Most utility organizations have SCADA systems in place (to varying degrees of complexity and depth into the system). Most SCADA schemes rely heavily on the experience and input of human Network Controllers to interpret and extrapolate System state and status from a minimal subset of the required information. SCADA provides data concentration and remote switching. SCADA does not provide complete information SCADA provides does not provide complete information concentration (having been designed for transmission and grid systems).

Most SCADA systems also rely heavily on central processing. Provided a significant amount of data collection and concentration are provided by a relatively small number of large RTU's (which does occur in generating and large transmission stations, central processing is not an issue. Where as in distributed control system central processing is distributed through system which makes it's controlling & monitoring fast & accurate. It provides complete and reliable information concentration. Graphics, logic, alarms, security, etc. Typically, the EWS is a PC running Windows 2000/XP

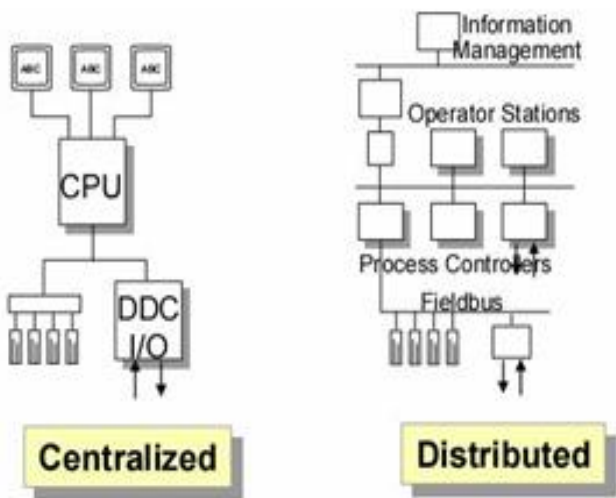

Figure.10 Comparison b/w SCADA and DCS

V. DISTRIBUTED CONTROL SYSTEM

A distributed system refers to a control system usually of a manufacturing system, process or any kind of dynamic system, in which the controller elements are not central in location (like the brain) but are distributed throughout the system with each component sub-system controlled by one or more controllers. The entire system of controllers is connected by a network for communication and monitoring [8, 9].

Architecture of DCS

1) Engineering Workstation

The Engineering Workstation (EWS) is for project

development, including configuration of

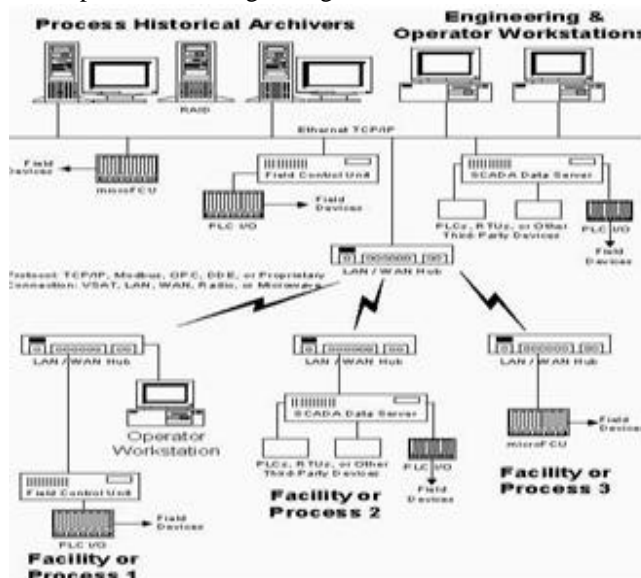

Figure.11 ARCHITECTURE OF DCS

2) Process Historical Archivers

The Process Historical Archives' (PHA) stores and retrieves historical data collected by the FCU, micro FCU, SDS, or any other intelligent device in the system. The PHA can run standalone or can share an OWS workstation.

3) Controllers

The Field Control Unit (FCU) executes sequential and regulatory logic and directly scans I/O. Depending on the FCU's configuration, you can scan multiple brands of I/O from one unit. The FCU runs QNX, a real-time operating system, and is typically a PLC industrial computer.

4) Networking and Communications

UCOS supports redundant and non-redundant fiber optic and Ethernet local networks using the TCP/IP networking protocol for standardized, advanced application connectivity.

5) Facility

This area illustrates a process that requires significant monitoring and control. A local operator uses the color graphic Operator Workstation (OWS) to monitor and control the process, and the Field Control Unit (FCU) executes sequential and regulatory control logic

Advantages of using DCS [10]

- 1) Modular and Scalable
- 2) Easy Implementation
- 3) Plug And Play
- 4) Reliability
- 5) Limited Distributed Intelligence
- 6) Less Cabling
- 7) Operate Under Fault Condition

VI. CONCLUSION

This paper discusses the control schemes for industrial automation and system monitoring to improve system operation, system reliability, asset management, etc. Various types of automation system such as relays, contactor logic, PLC's, SCADA and DCS has been discussed and we have

concluded that the new DCS, SCADA, and communication systems make it possible to integrate protection, control and monitoring together to its maximum benefits. The innovative development of automatic switching will yield more benefits to distribution utilities. Truly, distribution automation and system monitoring are the logical choice for the utilities to improve system performance, and to achieve customers and shareholders satisfactions.

REFERENCES

- [1] D.E. Seborg, T.F. Edgar, D.A. Mellichamp process dynamic and control, Wiley, 1989
- [2] G. Warnock, programmable controller: operation and application, Prentice Hall, 1988
- [3] Author: Lester Abbey managing director Abbey System Presented: Inaugural New Zealand SCADA Conference 28-29 October 2003, Auckland, NZ
- [4] HISTORY OF SCADA, (by Randy Dennison, EPG Companies Inc.) Sponsor "Energy Development and Power Generation Committee of the IEEE Power Engineering Society" The Institute of Electrical and Electronics Engineers, Inc. 345 East 47th Street, New York, NY 10017-2394, USA
- [5] Joe Mullaney, Senior Engineer, MSE Technology Applications, INC., Tetragenics Division
- [6] G. Baribaud et al., "Recommendations for the Use of Field buses at CERN in the LHC Era", Proceedings of the 1997 International Conference on Accelerator and Large Experimental Physics Control Systems, Beijing, 1997, p.285.
- [7] People in Control: An International Conference on
- [8] Human Interfaces in Control Rooms, Cockpits and Command Centers 21 - 23 June 1999, Conference Publication No. 463, O IEE, 1999.
- a. Tabisz, Jovanic, & Lee,; "Present and Future of Distributed Power Systems," APEC Proceedings, February 1992.
- [9] Gordon Clarke, Senior Researcher, Edwin Wright
- [10] Practical Modern SCADA Protocol, Proceedings of IEEE, Newness 2004.
- [11] Bretz, E.A. "By-Wire cars turn the corner" IEEE Spectrum, Vol. 38, no. 4, pp.68-73, April 2001.
- Michael Perz, "SONET-Based System Enhances Reliability", Transmission & Distribution World, Vol. 52, No. 10, October 2000.
- [12] S. Sabir and H. Mahoney, "Building a Backbone for Integrated Business Communications", IEEE Computer Applications in Power, Jan 1996.
- [13] Intech -open.com, abstract from automation Edited by Florian Kongoli ISBN 978-953-51-0685-2, Hard cover, 548 pages, Publisher: InTech, Published: July 25, 2012 under CC BY 3.0 license, DOI: 10.5772/2327.