

# Smart street lamp Unit (SslU) with Embedded System

J Ferin Joseph, David Anthony Durand, V Gowtham

**Abstract**— The Smart street lamp Unit (SslU) is an advance lighting system. This system conserves energy by reducing light intensity and detects the damaged lights in a street. It uses sensors such as LDR and Ultrasonic. The LDR is used to sense the presents of light in morning to switch off the street lights automatically and the Ultrasonic sensor is used to sense object on the street to increase the intensity of the light. A relay is used to supply the different voltage to the street lights (half intensity and full intensity). Arduino microcontroller is used to control the sensors and the network of lights to work by the program loaded on the microprocessor. The main control center is notified if any damage or malfunction is detected using a GSM module. The process of error detection in this large hard-wired system is done using main control boxes or by using any wireless communicator for defined number of streets, the output commands to GSM module to alert the main control center.

**Index Terms**— Embedded Systems, MSP430 (microcontroller), Arduino (microprocessor), LDR sensor (Light presence checking sensor), Ultrasonic sensor (Object detecting sensor), GSM Module and relay

## I. INTRODUCTION

Accidents occurring in the night time are either caused by driver errors or malfunctioning street lights. The malfunctions can be caused by fused bulbs or damaged wiring. This SslU project reduces this error hence reducing accidents significantly. By detecting the faulty lights in a network and notifying it to the respective office by sending an alert through GSM module will be helpful to check and/or replace the damaged components. The embedded board combined with the sensors is called an embedded system, in this project the embedded board used is Arduino uno. It uses AT Mega microprocessor and the sensors used are LDR sensor and Ultrasonic sensor. The above mentioned sensors and the embedded board are described below and the complete embedded system circuit is displayed with its working and the program functionalities injected to the embedded board.

## II. EMBEDDED BOARD AND THE SENSORS

The Arduino uno embedded board uses AT Mega microprocessor. The microprocessor converts the sensor's output to usable parameters. It has 6 Analog pins, 1 Rx- Tx pair pins, 2 Vcc pin [3.3v and 5v], 3 Gnd pin, 13 Digital pins and a reset, test, PWM (Power Width Modulation) pins.

**J Ferin Joseph**, Electronics and Communication Engineering, St.Joseph's College of Engineering, Chennai-600119

**David Anthony Durand**, Electronics and Communication Engineering, St.Joseph's College of Engineering, Chennai-600119

**V Gowtham**, Electronics and Communication Engineering, St.Joseph's College of Engineering, Chennai-600119

Analog pins are used to give analog input (the input from LDR sensor) to the board from the sensor. The analog data is mostly a voltage value which purely depends on the sensitivity of sensor, the analog values will be converted to digital values by the ADC which is inbuilt of the board.

Digital pins will give binary output (0's and 1's). Hence the pins will either be ON or OFF. Some of these pins are used for the serial communication with some exceptional case sensors like Ultrasonic sensor and etc. PWM pins are Digital pins used to give accurate value form the sensor (Ultrasonic sensor) to the board.

The Rx- Tx pair pins are used to connect the board in serial with wireless communication modules like Bluetooth module, Xbee module and GSM module.

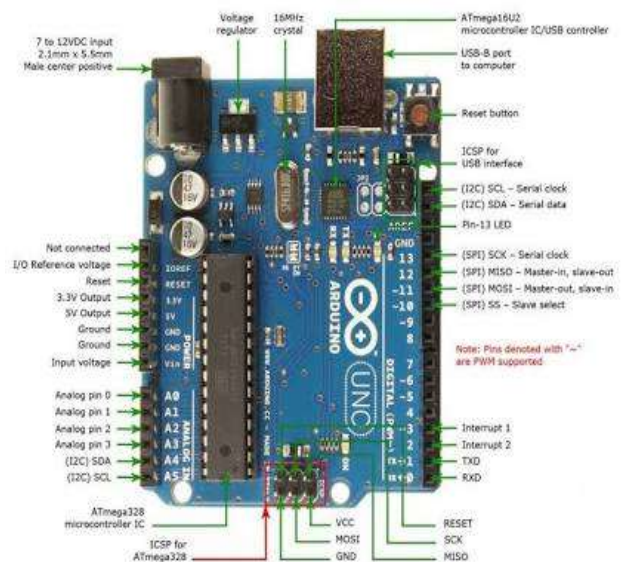

Figure 1. Arduino Uno with AT Mega microprocessor

### A. Abbreviations and Acronyms

Rx- Receiver, Tx- Transmitter, LDR- Light Dependent Resistor, PWM- Pulse Width Modulation.

### B. Other Recommendations

This SslU project can also be set up with MSP430 embedded microcontroller. It has similar Analog, Digital and Rx- Tx pins. MSP430 has 11 Digital pins, 6 Analog pins, 1 pair of Rx- Tx pins, 2 Vcc pins (3.3v and 5v), 3 Gnd pins. Among the digital pins some are used as the PWM pins for the exceptional case sensors like Ultrasonic sensors and etc..

Just like the Arduino board, in the MSP430 the Analog and the Digital pins have their own functions like getting the values from the sensors and some special pins like PWM (Power Width Modulation) are used to connect sensors like Ultrasonic sensor.

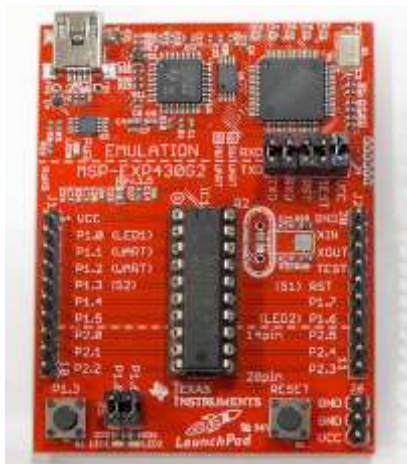

Figure 2. MSP430 interfaced with microcontroller unit

C. Sensors and Modules

There are different type of sensors available for Arduino uno board where in this project we use **Photo Resistor type** – LDR sensor, and **Reflection type** – Ultrasonic sensor.

1) LDR Sensor

LDR sensor can measure the light intensity in any given location. In this project the sensor performs the function of detecting the day light to automatically switch OFF and switch ON the street light.



Figure 3. LDR sensor



Figure 4. LDR Module

LDR sensor has two leads. It provides resistance to the circuit according to the intensity of light falling on it. LDR module is the embedded model of the LDR sensor, it has 3 pins of which the first and last pins are Vcc and Gnd, these pins are used to power the module. The center pin is the output pin which will be connected to an analog pin on the embedded board.

2) Ultrasonic Sensor

Ultrasonic sensor can measure the distance between the sensor and an object. In the SslU project it is used to detect an object on the road and to measure the length of the object, which in this case is a vehicle or a pedestrian. The length is measured to calculate the time durations the street light is to be at high intensity.



Figure 5. Ultrasonic sensor module

Ultrasonic sensor has 4 leads of which two are Vcc and Gnd pins. They are used to power the sensor. Trigger and Echo

pins are used to send the pulse and receive the pulse respectively. The time interval between the sending and receiving of the pulse is used to calculate the distance.

3) GSM Module

GSM Module is otherwise called a SIM module. It has two different functions 1) send SMS 2) internet access, in this project we use SIM800 module to send and receive SMS.



Figure 6. GSM Module

This module is used to send alerts if any damage is detected in a street lights.

III. MATH

For getting the Parameters from the different types of sensors Mathematics plays a major role.

A. Formula

As mentioned above the Analog pins can get the values in terms of analog voltage ie: voltage varying with some external parameters. For LDR sensor: the voltage varies with the amount of light falls on it. For Ultrasonic sensor: the voltage varies with the distance between the module and the object. Formulas are used to convert the analog value to the digital value so that the board can process and use the output of the sensors. In SslU all the sensors operate at the source of 5v. The 5v sensors transfer data at the rate of 1023 bits. The voltage value gained will be in millivolt (mv). The millivolt to parameter conversion is done with the below mentioned formula.

$$Voltage = ([sensor\_value] * 5.0) / 1023$$

This formula will be applied to the inputs from the sensors through analog pins and digital pins some exceptions are there due to sensors types. In SslU the reading from the LDR sensor and the Ultrasonic sensor where the LDR gives the voltage output with some variation so the above mentioned formula is applied but in case of Ultrasonic the inputs are taken with the PWM pins, so it have a different formula.

$$Value = (analog\ value / 2) //to\ get\ one\ length\ of\ pulse$$

$$Distance = Value / 56.8$$

LDR SENSOR CONVERSION

In this sensor when the light intensity is increased the resistivity is increased hence the voltage drops.

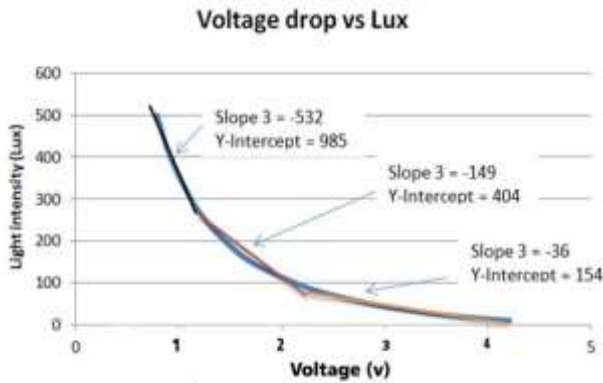

Figure 7. Graph representing the voltage and the LUX plot for LDR sensor

### ULTRASONIC SENSOR CONVERSION

For ultrasonic sensor the formula varies as mentioned above. Here the transmitting and the receiving time of the pulse is used to calculate the distance.

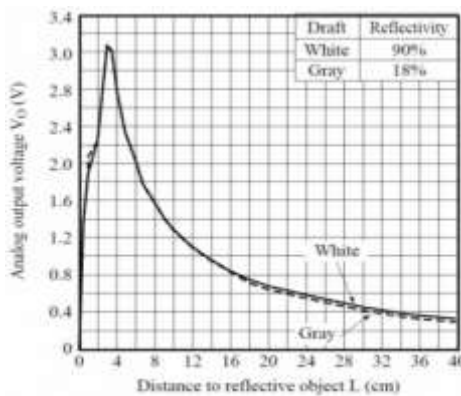

Figure 8. Graph representing the voltage and the distance plot for ultrasonic sensor

### IV. UNITS

The SI units calculated by the formula for the different sensors which are used in the SslU project are:

- LUX - Lumens per meter square (ldr sensor)
- m - meter (ultrasonic sensor)
- mv - millivolt

### V. CONNECTIONS

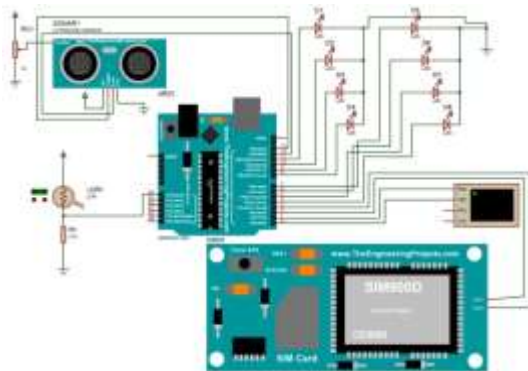

Figure.9 Circuit of the SslU with Arduino uno  
The Connection displayed above is the Smart street light System with the Arduino uno embedded board. It is paired with the GSM Module, sensor modules and the light (LED).

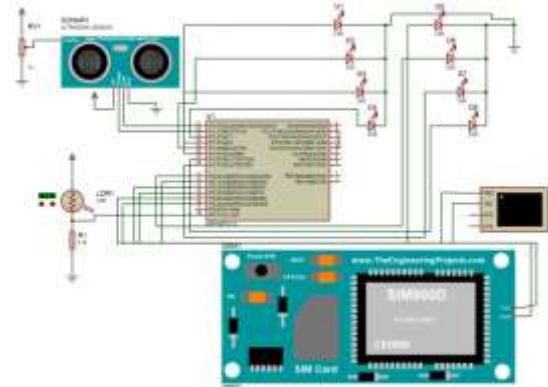

Figure 10. Circuit of the SslU with MSP430

The Connection displayed above is the Smart street light System with the MSP430 embedded board. It is paired with the GSM Module, sensor modules and the light (LED).

### VI. SOFTWARE AND IDE USED

The connections shown are simulated version of the SslU with both the Arduino and MSP430. They are simulated using the software: **Proteus 7**

#### Proteus 8

The programs are programmed in Integrated Development Environment (IDE): **Arduino IDE**

#### Energia IDE

Here Arduino IDE is for Arduino boards and the Energia IDE is for MSP430 boards.

### VII. PROGRAMMING

The following program samples are just the concept for controlling the SslU using Arduino or the MSP430.

```
39 /*****Function Definitions*****/
40 int getDist()
41 {
42     int dis;
43     unsigned long pulse=0;
44     digitalWrite(tri,HIGH);
48     delayMicroseconds(10);
49     digitalWrite(tri,LOW);
50
51     pulse=pulseIn(echo,HIGH);
52     pulse=pulse/2;
53     dis=pulse/58.2;
54
55     return dis;
56 }
```

The given code is a sample for declaring a function to detect the objects.

The formula will be used inside the loop function as each and every value from the output must be converted as per the parameters of the program to analyze.

### VIII. PRACTICAL DESIGN OF THE SSLU

This Smart street light System consist of a microcontroller or a microprocessor with the necessary sensors or modules, it also has communication devices or module with a supply battery. The microcontroller or microprocessor is an embedded board is powered up with a 5v or 9v supply. The sensors and communication devices are powered using 5v or



3.3v supply. Relays are used to provide the 12v power supply for the LED set using the 3v output from the embedded board. The complete connections are together called an embedded system.

### IX. FLOW CHART

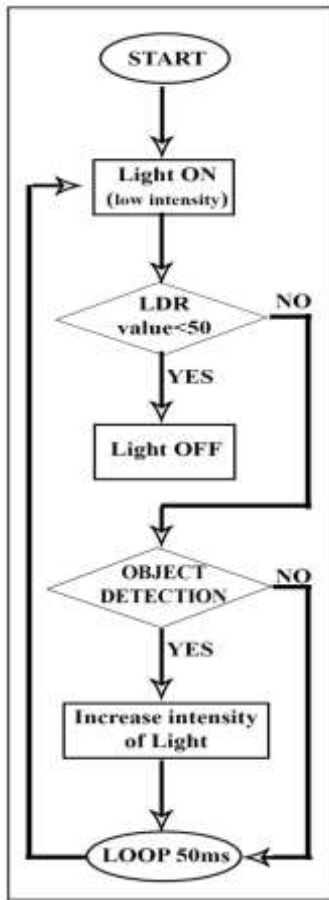

Figure 11. Flow chart for the working of SslU

### X. .CONCLUSION

The complete Software and Hardware which are used in this project is explained in the above headings. As mentioned under the heading "Embedded board and sensors" both Arduino430 and MSP430 can be used to design the SslU but using the MSP430 board is more efficient because it consumes lesser power and has a better data transfer rate when compared to the Arduino board. This SslU project can be applied in all cases or location of Street Lamps. The cost of practical application is very less and designing a model for this Unit is easy. The simulation model is constructed and output is verified with the working model.

### REFERENCES

- [1] Aishwarya.N.Patil, Ashwin Tripathi, and S.A.Fanan of Jawaharlal Darda Institute of Engineering, India, in Topic "Intelligent Street-Light System using Arduino UNO", published in 2017.
- [2] Monika Vaghela, Harshil Shah, Hardik Jayswal, Hitesh Patel in Topic "Arduino Based Auto Street Light Intensity Controller" published in Inverti Rapid: Embedded Systems Vol. 2017, Issue 3.
- [3] Giuseppe Parise. Electrical safety of street light systems. **IEEE Transaction on Power Delivery**, 26(3)1952-1959,2011.
- [4] Donald A Cleland, in Topic "Street light monitoring and control". United States of America Patent US 8,290,710 B2, 16 October 2012.
- [5] Maheshkumar Narsayya Bhairi, Shubhangi Shital Kangle, and Manohar Suresh Edake, of Electrical Engineering Departmane, NK

- ORCHID, in Topic "Design and implementation of smart solar LED street light" in **IEEE DOI:10.1109/ICOEL.2017.80090**.
- [6] P P Fathima Dheena, Greema S Raj and Gopika Dutt of Department of Aerospace Engineering, Noorul Islam University, in Topic "IOT based smart street light management system", in **IEEE DOI: 10.1109/ICCS1.2017.8326023**.
- [7] Deepak Kumar Rath of "Instrumentation & Electronics Engineering" in Topic "Arduino Based: Smart Light Control System" in International Journal of Engineering Research and General Science, Volume 4, Issue 2, March 2016.
- [8] Harshit Satyaseel, Gaurav Sahu, Manisha Agarwal and Jagrity Priya, in Topic "Light Intensity Monitoring & Automation of Street Light Control by IOT" in **ISSN 2347-8616**, October 2017.
- [9] Swadhin Meher of Electrical Engineering, National Institute of Technology, India, in Topic "Design and implementation of Smart-street light system using ArduinoUNO".
- [10] Jha Ashish K, Bababe Adam, Ishan Ranjan in Topic "Smart Street Light Management System using LoRa Technology" in **IJSR, ISSN (online): 2319-7064**.